

ISOS™

Inflatable Shut Off Seal

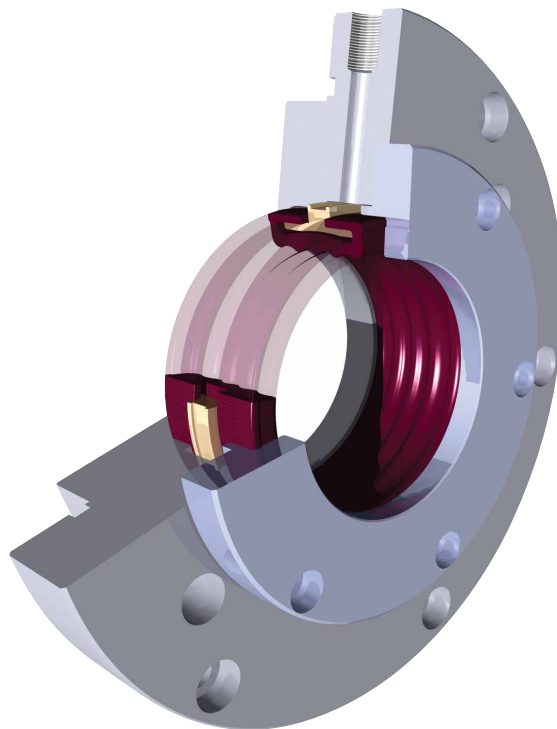

- For use in conjunction with radially divided seals
- Allows easier and quicker replacement of a mechanical seal without having to drain equipment
- Allows replacement of seal when pump shut off valves are faulty
- Eliminates the need for pump shut off valves when replacing seal
- No re-priming of pumps needed after seal replacement
- Once inflated by a suitable and continuous supply it forms a pressurized seal for zero product leakage

ISOS™ - inflatable shut off seal

Most engineers will relate to the problems encountered when installing or removing a radially divided mechanical seal from rotating equipment.

However, the biggest single problem is that the whole system has to be drained or isolated so that liquids do not pour out when the seal is removed. This can sometimes take hours or even days depending on the application - all lost production time.

Introducing the AESSEAL® ISOS™ - the Inflatable Shut Off Seal, which solves this major problem.

The ISOS™, which is fitted between the pump and radially divided seal, forms a separate seal when required, allowing the quick and easy removal of the mechanical seal.

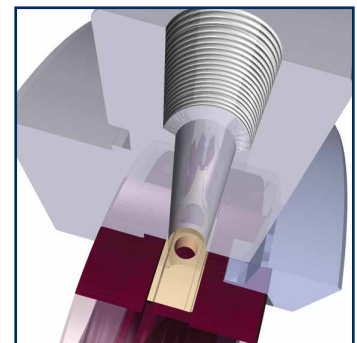
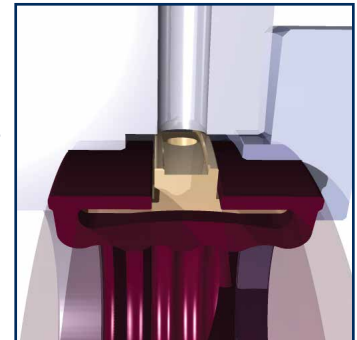
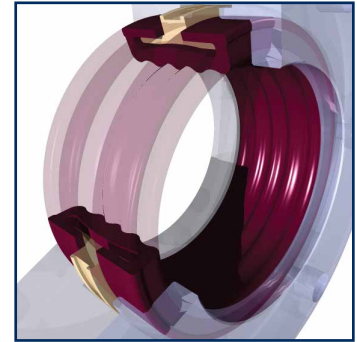
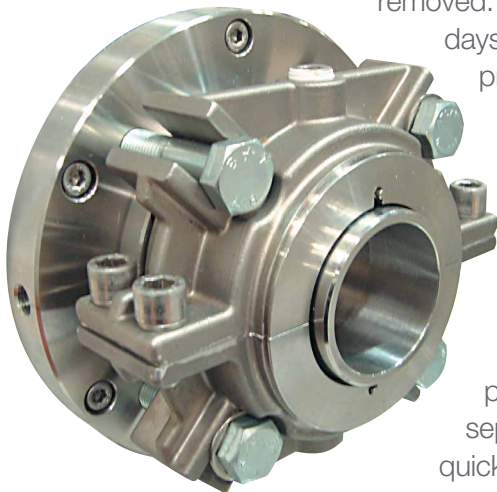

ISOS™ and RDSTM shown together

The ISOS™ works around the principle of surrounding the shaft with an inflatable elastomeric bladder. Under normal operating conditions, when the mechanical seal is working, the bladder remains unpressurized.

When the mechanical seal fails or needs removing, the bladder can be inflated thereby mechanically sealing the shaft. The seal can then be easily removed without draining or isolating the equipment.

Note - can be pressurized by air or water.

ISOS™ - Inventoried Bladder Sizes

Imperial (Inches)	Metric (mm)
2.500	63
2.750	70
3.000	75
3.500	90
4.000	100
5.000	127
9.625	245

All metal components are designed to suit the application and made to order only.

Item	Description	Material
1	Main Housing	316L Stainless Steel
2	Housing O Ring	FKM / EPR / FFKM / TFE/P
3	Inflatable Bladder	EPR
4	Inner Ring	316L Stainless Steel
5	Bladder O Ring	FKM / EPR / FFKM / TFE/P
6	Cover Plate	316L Stainless Steel
7	Caphead Bolt	Stainless Steel

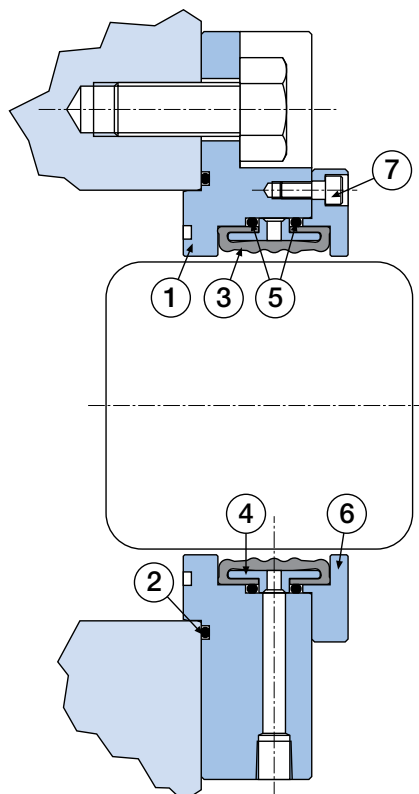

ISOS™ - operation using the AESSEAL® RDS™ Mechanical Seal

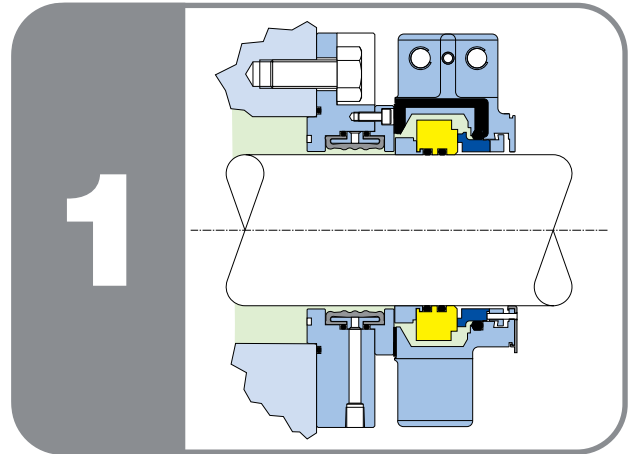
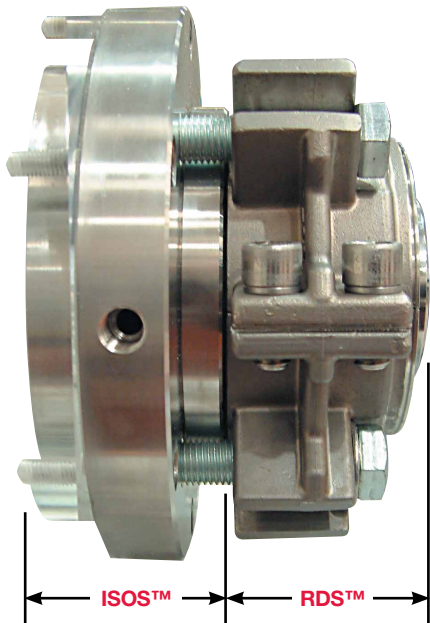

Seal in operation. The bladder is uninflated.

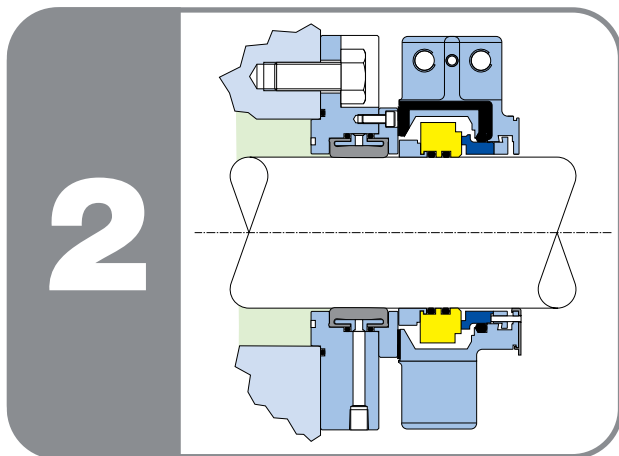

The pump is stopped, the Bladder is inflated and then seals onto the shaft. The radially divided seal can then be drained of fluid by its flush port.

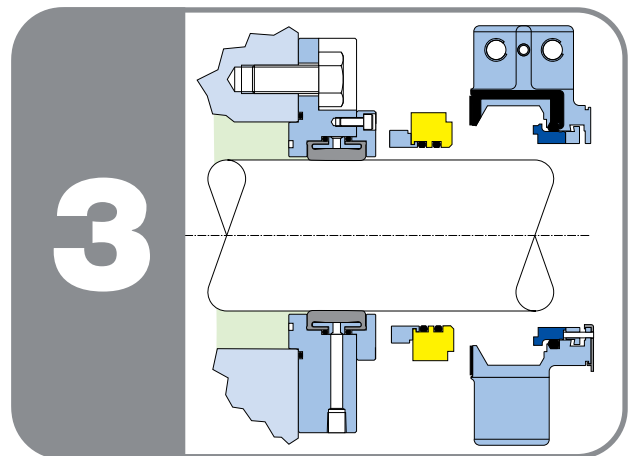

Whilst the bladder is inflated the seal is replaced.

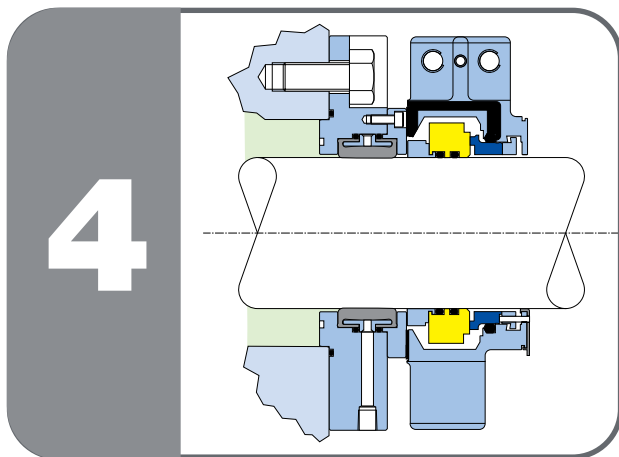

Bladder is still inflated and a new seal is installed.

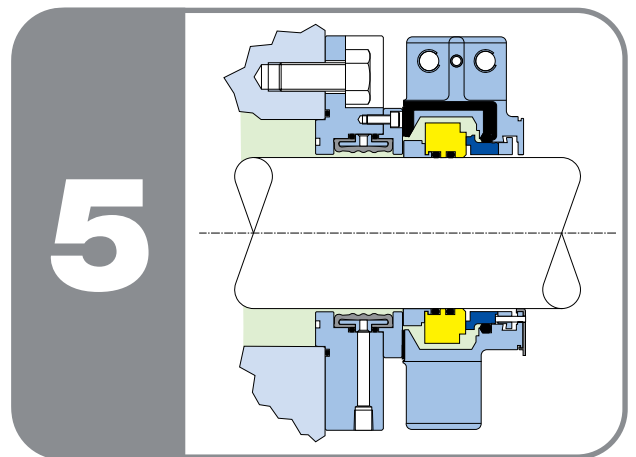

Bladder is deflated, the seal is primed and set to run again.

RDS™ - Radially Divided Seal

The AESSEAL® RDS™ (Radially Divided Seal) is an ideal seal to be used in conjunction with the ISOS™ due to its unique separation technology.

The RDS™ mechanical seal has been designed to be the fastest two-part seal to install in the market place and includes the following features:

- Minimum parts to assemble
- Patented assembled spring retainer
- External, visible indicator of correct installation
- Balanced stationary design with large internal clearances
- Unique patented 'O' Ring design
- Sizes available from 2.500" to 12.000" (63mm to 300mm)

It represents a significant advancement in separation technology and bridges the gap between pump packing and conventional mechanical seals.

Significant product development and dynamic testing were aimed at ensuring that the operating performance of the RDS™ seal would be predictable.



This brochure is available by contacting the Marketing department at marketing@aes seal.com or can be downloaded by visiting our website at www.aes seal.com



 This brochure is fully recyclable. When laminated, a sustainable, biodegradable and recyclable lamination is used. 

For further information and safe operating limits contact our technical specialists at the locations below.



UK Sales & Technical advice:

AESSEAL plc
Mill Close
Bradmarsh Business Park
Rotherham,
S60 1BZ, UK
Tel: +44 (0) 1709 369966
E-mail: enquiries@aes seal.info
www.aes seal.com

AESSEAL plc is certified to:

ISO 9001, ISO 14001, ISO/IEC 20000, ISO/IEC 27001,
ISO/TS 29001, ISO 37001, ISO 45001 & ISO 50001



Net Zero champions globally



Use double mechanical seals with hazardous products.

Always take safety precautions:

- Guard your equipment
- Wear protective clothing



USA Sales & Technical advice:

AESSEAL Inc.
355 Dunavant Drive
Rockford,
TN. 37853,
USA

Tel: +1 865 531 0192
E-mail: usa@aes seal.com
www.aes seal.com

Important: Since the conditions and methods of use of this product are beyond our control, AESSEAL plc expressly disclaims any and all liability resulting or arising from any use of this product or reliance on any information contained in this document - AESSEAL plc standard conditions of sale apply. All sizes are subject to manufacturing tolerances. We reserve the right to modify specifications at any time. AESSEAL® is a Registered Trademark of AES Engineering Ltd, AESSEAL plc recognizes all trademarks and trademark names as the property of their owners.