

RDSX™

Radially Divided Seal Range



- Minimum parts to assemble
- Patented assembled spring retainer
- External, visible indicator of correct installation
- Balanced stationary design with large internal clearances
- Unique 'O' ring design

RDSX™ — Radially Divided Seal

The RDSX™ seal eliminates the need to remove or strip equipment for seal replacement. The self-aligning rotary makes the RDSX™ one of the easiest and quickest to install split seals on the market today.



RDSX™ Features

- Self-aligning stationary and rotary seal faces
- Installation wear indicator
- Hydraulically balanced seal-faces
- Patented assembled spring retainer
- Unique 'O'ring design
- Minimum parts

Benefits

- Enables quick and successful installation and a long seal life.
- Shows seal is correctly installed and indicates seal life.
- Reduces seal-face loading, maximizing seal life and allowing for vacuum service capability
- Springs are not under compression during installation
- Predictable and simple joining and assembly
- Quick and easy to assemble

The RDSX™ has been developed after extensive research and customer feedback to increase the ease of fitting the seal correctly – first time.

A comprehensive product development and dynamic testing process makes the RDSX™ the ideal product to offer mechanical seal benefits over traditional packing solutions without increasing maintenance costs or downtime.

Key applications

- Pulp & Paper
- Clean Water
- Large equipment
- Inexpensive and difficult maintenance situations

Self-aligning Seal

The RDSX™ with its spring-loaded stationary is specifically designed to accommodate typical misalignment problems.

In addition clearances have been optimized between the rotary and stationary members and the gland halves, which minimizes dead-ending or solidification problems that could be present in a stationary seal that had minimal clearances, particularly around the outside diameter of the stationary.

Installation and Wear Indicator

The stationary anti-rotation pin acts as an indicator that the RDSX™ seal has been properly installed, before pressurising and running the equipment.

As the seal ages, the end of the pin will move progressively towards the RDSX™ gland as wear takes place, providing an indication of the remaining seal life. When the end of the pin is level with the gland, the RDSX™ seal face replacement kit should be installed.

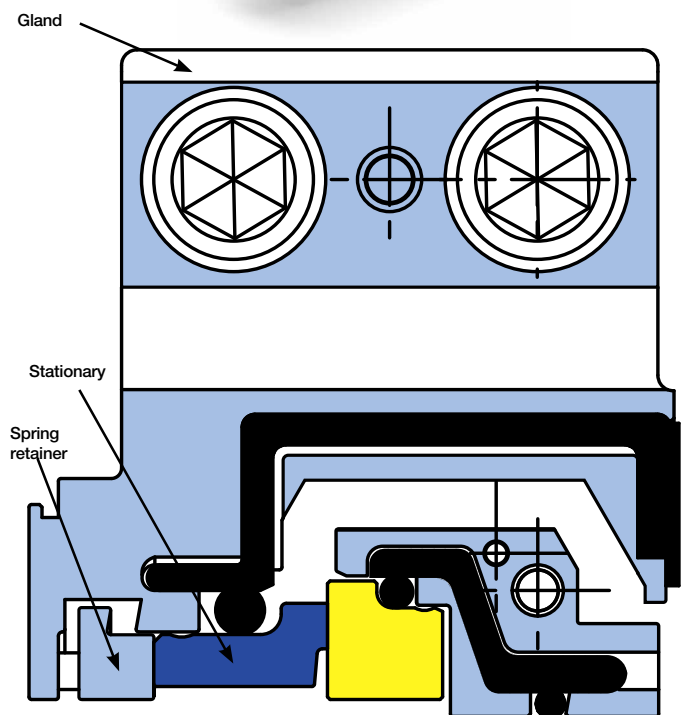

RDSX™ seal anti rotation setting and wear indicator pin arrangement

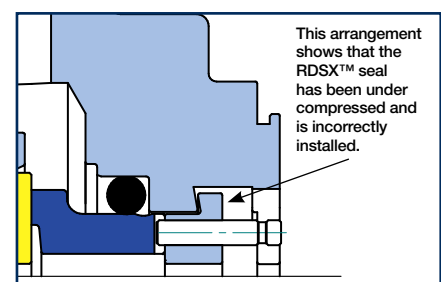
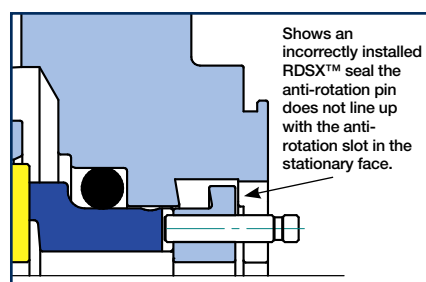
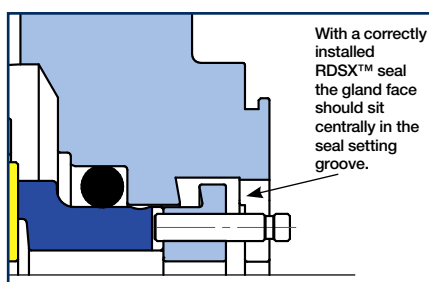

Where no emissions or leakage, even on an occasional basis, can be tolerated, our radially divided mechanical seal should not be installed.

Design Concept

The most important single objective was to design a radially divided seal that was easy to install. This was achieved by having the smallest possible number of parts to assemble.

The entire seal assembly comprises of only three 'O' rings, two rotary halves, two stationary halves and two gland cartridge halves, which include the springs and spring retainer. The only other parts are socket set screws and Allen keys.

A pre-assembled patented spring retainer ensures the springs are not under compression during the initial assembly. All seal parts are assembled, fixed to the shaft and tightened, before loading the springs, which are only compressed when the seal assembly is bolted to the face of the stuffing box.

The elastomer seals for both the rotary face and gland assembly have been designed to simplify installation.

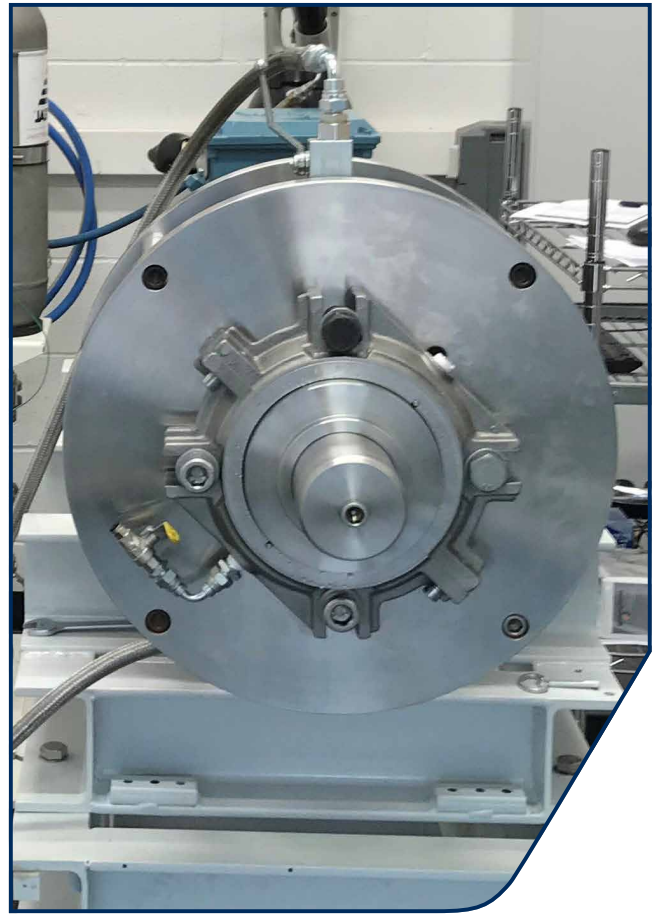

Dynamic test rig with 7.500" (190mm) RDSX™ installed



RDSX™ face testing equipment

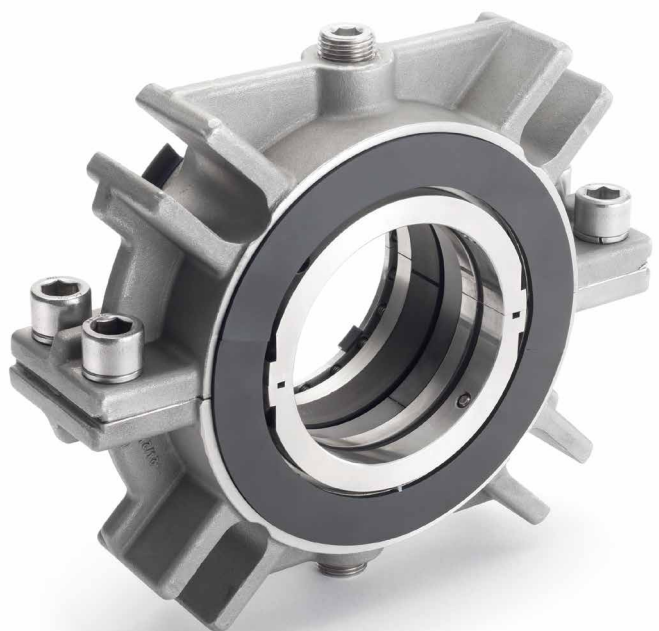



Gland Half Location and Bolting Detail

Gland Bolting Detail

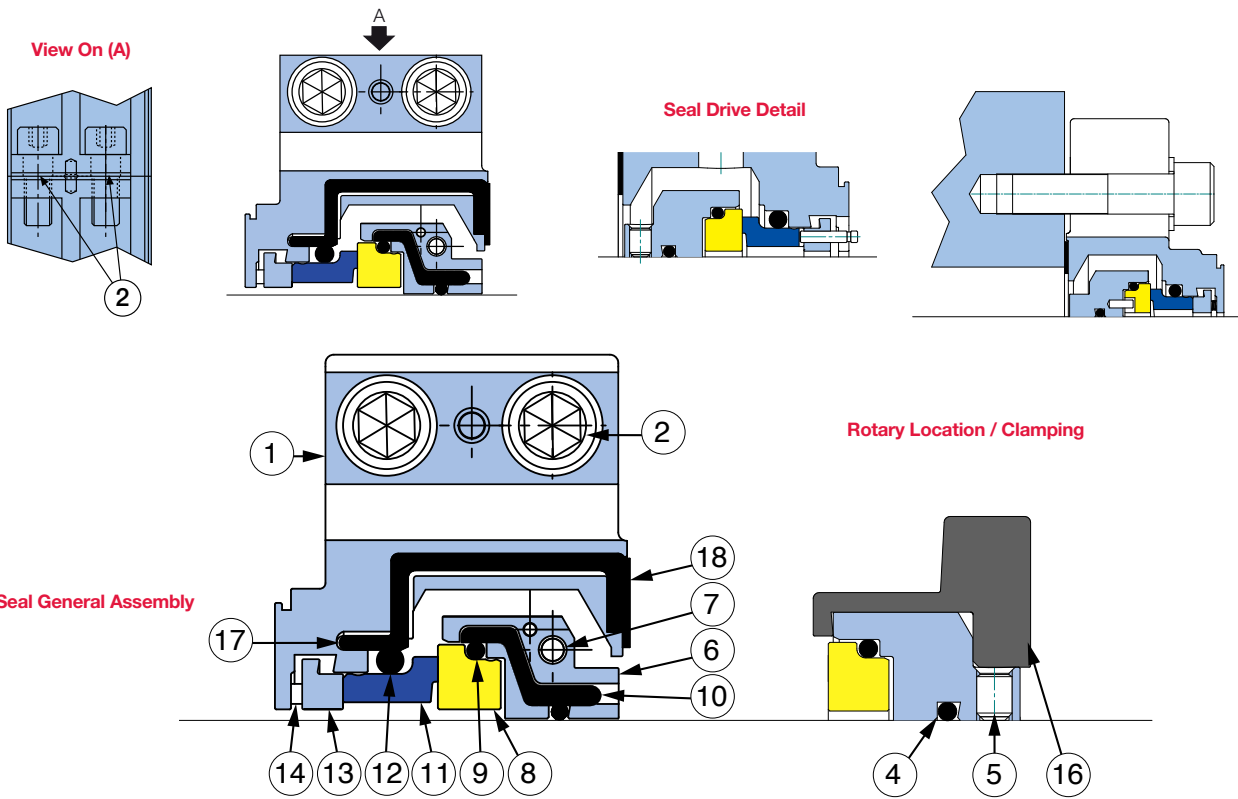

ITEM	DESCRIPTION	MATERIAL
1	Gland	316 SS
2	Gland Bolts	SS
3*	Centering Clips	Plastic
4	Shaft 'O' ring	FKM / TFE/P
5	Drive Screw	SS
6	Rotary Holder	316L SS
7	Rotary Caphead	SS
8	Rotary Face	SiC
9	Rotary 'O' ring	FKM / TFE/P

ITEM	DESCRIPTION	MATERIAL
10	Rotary Holder Gasket	FKM / TFE/P
11	Stationary Face	Carbon/SiC
12	Stationary 'O' ring	FKM / TFE/P
13	Spring Retainer	316L SS
14	Springs	Alloy 276
15*	Anti-Rotation Pins	316 SS
16	Rotary Setting Clips	Plastic
17	Gland 'U' Gasket	FKM / TFE/P
18	Gland Face Gasket	FKM / TFE/P

* Item not shown

“ Our purpose is to give our customers such exceptional service that they need never consider alternative sources of supply. ”

RDSX™ — Technical Information

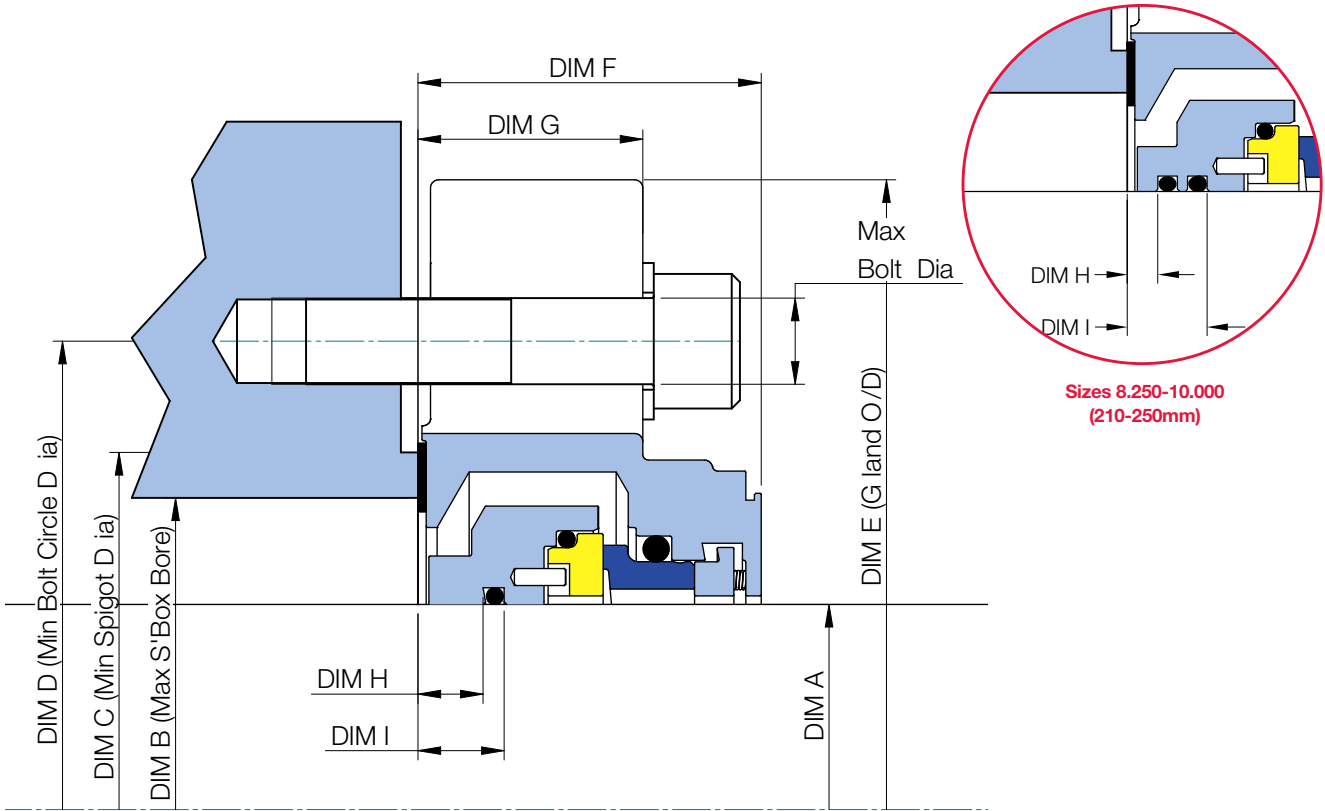

Adaptor plates available, contact the AESSEAL® technical department

RDSX™ — Dimensional Information (inches)

DIM A	DIM B	DIM C	DIM D	DIM E	DIM F	DIM G	DIM H	DIM I	Max Bolt Ø
-------	-------	-------	-------	-------	-------	-------	-------	-------	------------

2.500" - 2.625" RDSX™ seal from -21 casting (Small Range)

2.500	3.750	4.250	5.125	6.500	1.883	1.659	0.417	0.514	0.625
2.625	3.750	4.250	5.125	6.500	1.883	1.659	0.417	0.514	0.625

2.625" - 2.750" RDSX™ seal from -22 casting

2.625	4.250	4.750	5.687	7.750	2.500	1.750	0.450	0.650	0.625
2.750	4.250	4.750	5.687	7.750	2.500	1.750	0.450	0.650	0.625

2.500" - 3.000" RDSX™ seal from -24/21 casting

2.500	4.500	5.000	5.937	8.000	2.500	1.750	0.450	0.650	0.625
2.875	4.500	5.000	5.937	8.000	2.500	1.750	0.450	0.650	0.625
3.000	4.500	5.000	5.937	8.000	2.500	1.750	0.450	0.650	0.625

2.500" - 3.250" RDSX™ seal from -26/20 casting

3.125	4.750	5.250	6.250	8.250	2.500	1.750	0.450	0.650	0.625
3.250	4.750	5.250	6.250	8.250	2.500	1.750	0.450	0.650	0.625

2.625" - 3.500" RDSX™ seal from -28/22 casting

3.375	5.000	5.500	6.562	8.500	2.500	1.750	0.450	0.650	0.750
3.500	5.000	5.500	6.562	8.500	2.500	1.750	0.450	0.650	0.750

RDSX™ — Dimensional Information (mm)

DIM A	DIM B	DIM C	DIM D	DIM E	DIM F	DIM G	DIM H	DIM I	Max Bolt Ø
-------	-------	-------	-------	-------	-------	-------	-------	-------	------------

63mm - 65mm RDSX™ seal from -21 casting (Small Range)

63	95.3	108.0	130.2	165.1	47.8	42.1	10.6	13.1	16.0
65	95.3	108.0	130.2	165.1	47.8	42.1	10.6	13.1	16.0

65mm - 70mm RDSX™ seal from -22 casting

65	108.0	120.7	144.4	196.9	63.5	44.5	11.5	16.5	16.0
70	108.0	120.7	144.4	196.9	63.5	44.5	11.5	16.5	16.0

65mm - 75mm RDSX™ seal from -24/21 casting

75	114.3	127.0	150.8	203.2	63.5	44.5	11.5	16.5	16.0
----	-------	-------	-------	-------	------	------	------	------	------

65mm - 80mm RDSX™ seal from -26/20 casting

80	120.7	133.4	158.8	209.6	63.5	44.5	11.5	16.5	16.0
----	-------	-------	-------	-------	------	------	------	------	------

65mm - 85mm RDSX™ seal from -28/22 casting

85	127.0	139.7	166.7	215.9	63.5	44.5	11.5	16.5	20.0
----	-------	-------	-------	-------	------	------	------	------	------

All specified sizes are planned inventory item. For details on sizes not shown contact AESSEAL®



RDSX™ – Dimensional Information (inches)

DIM A	DIM B	DIM C	DIM D	DIM E	DIM F	DIM G	DIM H	DIM I	Max Bolt Ø
-------	-------	-------	-------	-------	-------	-------	-------	-------	------------

2.875" - 3.750" RDSX™ seal from -30/24 casting

3.625	5.250	5.750	6.750	8.750	2.500	1.750	0.450	0.650	0.750
3.750	5.250	5.750	6.750	8.750	2.500	1.750	0.450	0.650	0.750

3.125" - 4.000" RDSX™ seal from -32/26 casting

3.875	5.500	6.000	7.062	9.000	2.500	1.750	0.450	0.650	0.750
4.000	5.500	6.000	7.062	9.000	2.500	1.750	0.450	0.650	0.750

3.625" - 4.500" RDSX™ seal from -36/30 casting

4.250	6.000	6.500	7.562	9.500	2.500	1.750	0.450	0.650	0.750
4.375	6.000	6.500	7.562	9.500	2.500	1.750	0.450	0.650	0.750
4.500	6.000	6.500	7.562	9.500	2.500	1.750	0.450	0.650	0.750

4.125" - 5.000" RDSX™ seal from -40/34 casting

4.750	6.500	7.000	8.062	11.000	2.500	1.750	0.818	1.120	0.750
4.875	6.500	7.000	8.062	11.000	2.500	1.750	0.818	1.120	0.750
5.000	6.500	7.000	8.062	11.000	2.500	1.750	0.818	1.120	0.750

5.125" - 5.500" RDSX™ seal from -44 casting

5.125	7.500	8.000	9.000	11.750	3.187	2.375	0.530	0.666	1.000
5.250	7.500	8.000	9.000	11.750	3.187	2.375	0.530	0.666	1.000
5.500	7.500	8.000	9.000	11.750	3.187	2.375	0.530	0.666	1.000

5.750" - 6.000" RDSX™ seal from -48 casting

5.750	8.000	8.500	9.500	12.250	3.187	2.375	0.530	0.666	1.000
6.000	8.000	8.500	9.500	12.250	3.187	2.375	0.530	0.666	1.000

6.250" - 6.500" RDSX™ seal from -52 casting

6.250	8.500	9.000	10.000	12.750	3.187	2.375	0.530	0.666	1.000
6.500	8.500	9.000	10.000	12.750	3.187	2.375	0.530	0.666	1.000

6.750" - 7.000" RDSX™ seal from -56 casting

6.750	9.000	9.500	10.500	13.250	3.437	2.625	0.744	0.880	1.000
7.000	9.000	9.500	10.500	13.250	3.437	2.625	0.744	0.880	1.000

7.250" - 7.500" RDSX™ seal from -60 casting

7.250	9.500	10.000	11.000	13.750	3.437	2.625	0.744	0.880	1.000
7.500	9.500	10.000	11.000	13.750	3.437	2.625	0.744	0.880	1.000

7.750" - 8.000" RDSX™ seal from -64 casting

7.750	10.250	11.000	12.250	16.000	3.660	3.187	0.855	0.992	1.000
8.000	10.250	11.000	12.250	16.000	3.660	3.187	0.855	0.992	1.000

8.250" - 8.500" RDSX™ seal from -68 casting

8.250	10.750	11.500	12.750	16.500	3.660	3.187	0.570	0.960	1.000
8.500	10.750	11.500	12.750	16.500	3.660	3.187	0.570	0.960	1.000

8.750" - 9.000" RDSX™ seal from -72 casting

8.750	11.250	12.000	13.250	17.000	3.660	3.187	0.570	0.960	1.000
9.000	11.250	12.000	13.250	17.000	3.660	3.187	0.570	0.960	1.000

9.250" - 9.500" RDSX™ seal from -76 casting

9.250	11.750	12.500	13.750	17.500	3.660	3.187	0.570	0.960	1.000
9.500	11.750	12.500	13.750	17.500	3.660	3.187	0.570	0.960	1.000

9.625" - 10.000" RDSX™ seal from -80 casting

9.625	12.250	13.000	14.250	18.000	3.875	3.187	0.570	0.960	1.000
9.750	12.250	13.000	14.250	18.000	3.875	3.187	0.570	0.960	1.000
10.000	12.250	13.000	14.250	18.000	3.875	3.187	0.570	0.960	1.000

RDSX™ – Dimensional Information (mm)

DIM A	DIM B	DIM C	DIM D	DIM E	DIM F	DIM G	DIM H	DIM I	Max Bolt Ø
-------	-------	-------	-------	-------	-------	-------	-------	-------	------------

75mm - 95mm RDSX™ seal from -30/24 casting

90	133.4	146.1	171.5	222.3	63.5	44.5	11.5	16.5	20.0
95	133.4	146.1	171.5	222.3	63.5	44.5	11.5	16.5	20.0

80mm - 100mm RDSX™ seal from -32/26 casting

100	139.7	152.4	179.4	228.6	63.5	44.5	11.5	16.5	20.0
-----	-------	-------	-------	-------	------	------	------	------	------

90mm - 110mm RDSX™ seal from -36/30 casting

105	152.4	165.1	192.1	241.3	63.5	44.5	11.5	16.5	20.0
110	152.4	165.1	192.1	241.3	63.5	44.5	11.5	16.5	20.0

105mm - 125mm RDSX™ seal from -40/34 casting

120	165.1	177.8	204.8	279.4	63.5	44.5	20.7	28.4	20.0
125	165.1	177.8	204.8	279.4	63.5	44.5	20.7	28.4	20.0

130mm - 140mm RDSX™ seal from -44 casting

130	190.5	203.2	228.6	298.4	80.9	60.3	13.5	16.9	25.0
135	190.5	203.2	228.6	298.4	80.9	60.3	13.5	16.9	25.0
140	190.5	203.2	228.6	298.4	80.9	60.3	13.5	16.9	25.0

145mm - 150mm RDSX™ seal from -48 casting

145	203.2	215.9	241.3	311.1	80.9	60.3	13.5	16.9	25.0
150	203.2	215.9	241.3	311.1	80.9	60.3	13.5	16.9	25.0

160mm - 165mm RDSX™ seal from -52 casting

160	215.9	228.6	254.0	323.8	80.9	60.3	13.5	16.9	25.0
165	215.9	228.6	254.0	323.8	80.9	60.3	13.5	16.9	25.0

170mm - 175mm RDSX™ seal from -56 casting

170	228.6	241.3	226.7	336.5	87.3	66.7	18.9	22.4	25.0
175	228.6	241.3	226.7	336.5	87.3	66.7	18.9	22.4	25.0

180mm - 190mm RDSX™ seal from -60 casting

180	241.3	254.0	279.4	349.2	87.3	66.7	18.9	22.4	25.0
190	241.3	254.0	279.4	349.2	87.3	66.7	18.9	22.4	25.0

195mm - 200mm RDSX™ seal from -64 casting

195	260.4	275.4	311.2	406.4	93.0	81.0	21.7	25.2	25.0
200	260.4	275.4	311.2	406.4	93.0	81.0	21.7	25.2	25.0

210mm - 215mm RDSX™ seal from -68 casting

210	273.0	292.1	323.9	419.1	93.0	81.0	14.5	24.5	24.0
215	273.0	292.1	323.9	419.1	93.0	81.0	14.5	24.5	24.0

220mm - 225mm RDSX™ seal from -72 casting

220	285.8	304.8	336.6	431.8	93.0	81.0	14.5	24.5	24.0
225	285.8	304.8	336.6	431.8	93.0	81.0	14.5	24.5	24.0

230mm - 240mm RDSX™ seal from -76 casting

230	298.5	317.5	349.3	444.5	93.0	81.0	14.5	24.5	24.0
240	298.5	317.5	349.3	444.5	93.0	81.0	14.5	24.5	24.0

245mm - 250mm RDSX™ seal from -80 casting

245	311.0	330.2	361.9	457.2	98.4	81.0	14.5	24.5	24.0
250	311.0	330.2	361.9	457.2	98.4	81.0	14.5	24.5	24.0

ABOVE 10.000" (250mm) PLEASE CONSULT AESSEAL FOR AVAILABILITY

All specified sizes are planned inventory item. For details on sizes not shown contact AESSEAL®



ENVIRONMENTAL TECHNOLOGY

To experience the exceptional, please contact your local representative. Discover full details on our website:

www.aesseal.com

This brochure is fully recyclable. When laminated, a sustainable, biodegradable and recyclable lamination is used.

For further information and safe operating limits contact our technical specialists at the locations below.



UK Sales & Technical advice:

AESSEAL plc
 Mill Close
 Bradmarsh Business Park
 Rotherham,
 S60 1BZ, UK
 Tel: +44 (0) 1709 369966
 E-mail: enquiries@aesseeal.info
www.aesseal.com

AESSEAL plc is certified to:

ISO 9001, ISO 14001, ISO/IEC 20000, ISO/IEC 27001,
 ISO/TS 29001, ISO 37001, ISO 45001 & ISO 50001



Net Zero champions globally



Use double mechanical seals with hazardous products.



Always take safety precautions:

- Guard your equipment
- Wear protective clothing

USA Sales & Technical advice:

AESSEAL Inc.
 355 Dunavant Drive
 Rockford,
 TN. 37853,
 USA

Tel: +1 865 531 0192
 E-mail: usa@aesseeal.com
www.aesseal.com

Important: Since the conditions and methods of use of this product are beyond our control, AESSEAL plc expressly disclaims any and all liability resulting or arising from any use of this product or reliance on any information contained in this document - AESSEAL plc standard conditions of sale apply. All sizes are subject to manufacturing tolerances. We reserve the right to modify specifications at any time. AESSEAL® is a Registered Trademark of AES Engineering Ltd, AESSEAL plc recognizes all trademarks and trademark names as the property of their owners.