

UDGS™ Universal Dry Gas Seal



Non Contacting Gas Lubricated Mechanical Seal

Effective containment of VOC emissions and contamination prevention of high value products





UDGS™

Universal Dry Gas Seal for pumps

Non-contacting, gas lift dual cartridge seal primarily designed for pumps (ANSI/DIN) providing practically **zero process emissions** in service.

The non-contacting nature of the design ensures long life, low power consumption and reduced capital cost for support systems. The buffer/barrier gas should be readily available and inert e.g. dry Nitrogen. One other major benefit is the ability to prevent contamination of high value products.

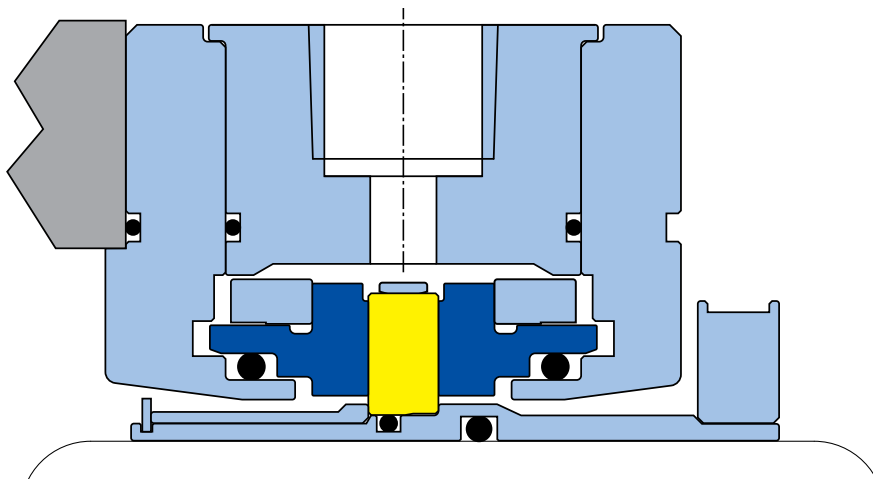

TYPICAL DUTIES

- Light Hydrocarbon applications
- Noxious chemicals
- Applications are typically <100 cSt Viscosity and contain no solids
- Pressures up to 21 barg (305 psig)
- Temperatures -40°C to +260°C (-40°F to +500°F) – elastomer dependent
- Peripheral speeds up to 25 m/s (5000 ft/min)

General Specification

Size range

20mm - 110mm (0.750" – 4.375")

Face options

(Soft / Hard / Soft) Antimony Carbon / Reaction Bonded Silicon Carbide / Antimony Carbon & (Hard / Hard / Hard) Graphite Sintered Silicon Carbide / Reaction Bonded Silicon Carbide / Graphite Sintered Silicon Carbide.

Elastomer options

FKM (Standard), EPR, NBR, TFE/P, FFKM

Gasket options

'O' ring (Standard), Graphite (Spiral Wound), AF1, GFT

Metallurgy options

Exotic product wetted metallurgy
DIN1.4462 (Duplex), Alloy 255 (Super Duplex), Alloy 276 etc.

KEY FEATURES / BENEFITS

- Gas lift hydrodynamic faces - low power requirement
- High efficiency gas lift seal face design.
- Minimum axial length due to face to face configuration.
- Can be fitted totally external to pump cavity.
- Designed for effective containment of VOC emissions.
- Face loading optimized, factory set and dynamically tested prior to despatch.
- Face design optimized using FEA.
- Allows simple cost effective support systems to be utilized.
- Barrier gas supply panels available, to ensure maximum seal reliability.



WARNING

Use double mechanical seals with hazardous products. Always take safety precautions:

- Guard your equipment
- Wear protective clothing

UDGS™ is a Trademark of AESSEAL plc, Registered Trademarks: AESSEAL® - AESSEAL plc, All other brand and product names are trademarks or registered trademarks of their respective holder.



Copyright © 2022 AESSEAL plc, Ref: DS-UK/US-UDGS-06

Contact

+44 (0)1709 369966
enquiries@aes seal.info

www.aes seal.com

IMPORTANT: Since the conditions and methods of use of this product are beyond our control, AESSEAL plc expressly disclaims any and all liability resulting or arising from any use of this product or reliance on any information contained in this document - AESSEAL plc standard conditions of sale apply.