

SECTION A-A

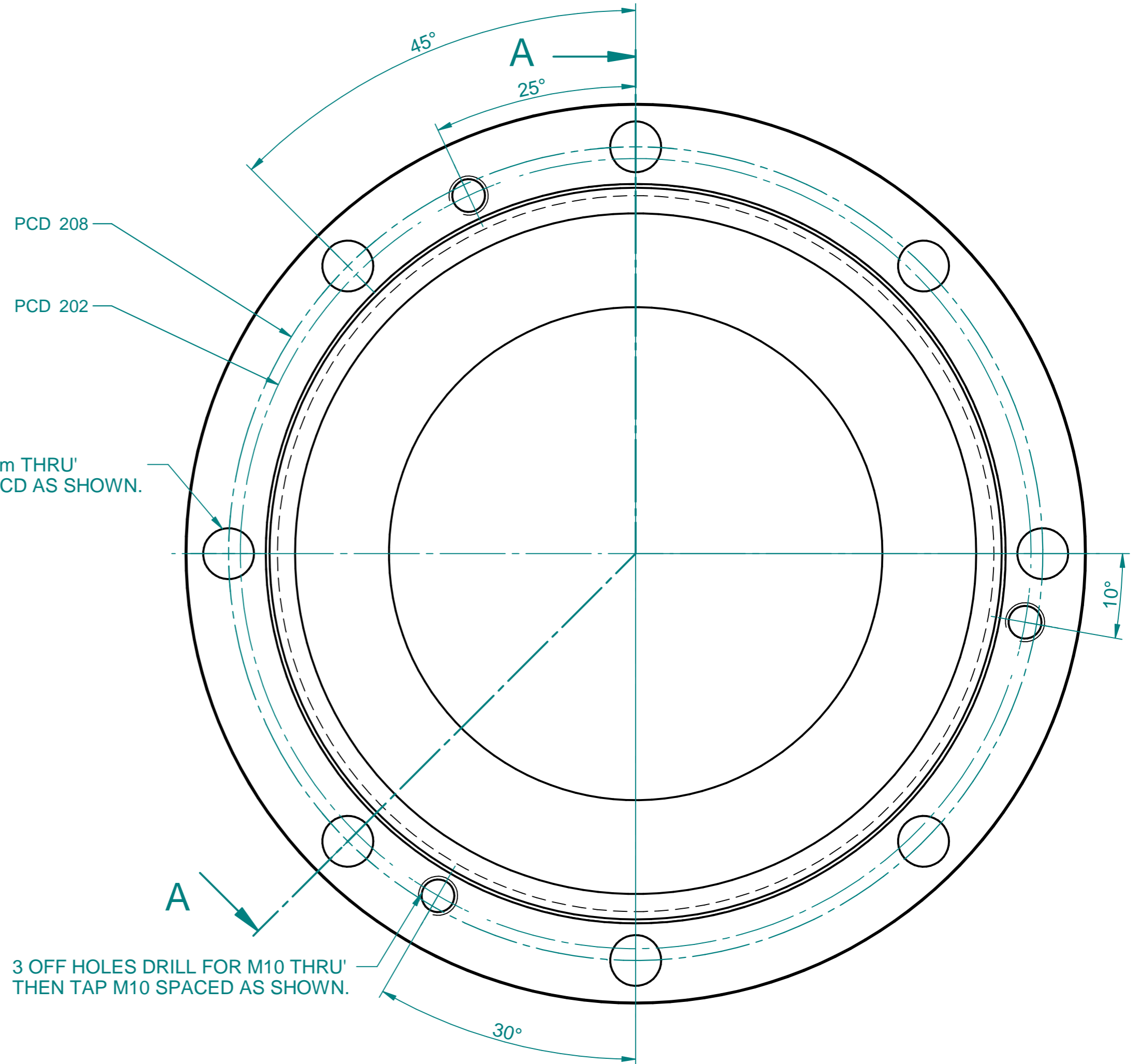

8 OFF HOLES Ø13mm THRU' EQUI-SPACED ON PCD AS SHOWN.

3 OFF HOLES DRILL FOR M10 THRU' THEN TAP M10 SPACED AS SHOWN.

NOTES:-
 1. REMOVE SHARP EDGES.
 2. MASS=3.815 kg

Item	Stock Code	Title	Material	Qty	ISSUE	AMEND No	DRN	AUTH	DATE
1	5SQ1123/01	1.375 CAPL TYS B3 DUAL SEAL	316L SS	1					
2	2SX1211/01	1.500 BCORG DRIVE END	316L SS	1					
3	DBVDB	DUMMY	316 L SS	1					
4		Heavy Hex Nut, 3/4-10	Steel	1					

UNSPECIFIED TOLERANCES

LINEAR: +/-0.01" (0.25mm)
 ANGULAR: +/- 30'
 SURFACE FINISH: 63 µin (1.6 µm)
 CONCENTRICITY: 0.002" (0.05mm) T.I.R

PROJECTION
 3RD ANGLE

UNITS
 MM UOS

SCALE
 1:1



AESSEAL plc
 BRADMARSH BUSINESS PARK
 MILL CLOSE, TEMPLEBOROUGH
 ROTHERHAM S60 1BZ

THIS DRAWING IS CONFIDENTIAL TO AESSEAL plc AND NEITHER THE DRAWING ITSELF, NOR ANY INFORMATION DERIVED FROM IT, SHOULD BE MADE PUBLIC, OR DIVULGED, EVEN IN CONFIDENCE TO ANOTHER PARTY WITHOUT THE EXPRESS PERMISSION OF AESSEAL plc. © COPYRIGHT AESSEAL plc AS SIGNED AND DATED.

DATE	29/02/2008	DRAWN	S Khedkar	CHECK	
SIG					

TITLE
 100mm WARMAN BEARING END PLATE(126mm)

MAT'L 316L SS SRM RS076/01
 STOCK CODE L1-126-02EED-WAR/01

DRG No 8010451 ISS. A